



FROMMM | AIRPAD
SYSTEMS

Complete aircushion solutions
for your protective packaging needs

Your challenges

Reliable protection, just in time

Ensuring customer's satisfaction

- The right protection to avoid damages
- Reliable, continuous operation for on-time delivery
- Light, clean, easily disposable protective materials

Controlling packaging cost

- The right pad format for your packaging needs
- The right film for producing your pads
- Complete integration into your packaging line
- The right accessories for your operators
- The right advice for optimizing your line

Optimizing your packing process

- Simplifying the packing process
- Optimum ergonomics and productivity
- Easy operation and fast training
- Quick integration of temporary personnel
- Quick response to peak seasons
- The right machine for your packaging line

FROMM – end-of-line packaging expertise for securing goods in transport.

Our solutions

The right film and the right pad

Sharing our experience

- Auditing your packing line
- Performing packaging cost analysis
- Recommending cost efficient solutions
- Full integration into packing line
- Optimizing pack station ergonomics and productivity

Covering all protection needs

- Wrapping
- Cushioning
- Block and brace
- Void filling

Protection during transport/storage

- Individual sealed or quilted pads
- Unsurpassed variety of pad configurations
- Heavy-duty, long shelf-life and antistatic films
- PE-PA, PET-PE, multilayer, laminated and coextruded films

Complete line integration

- Modular, scalable solutions
- Hoppers, mobile bins and winders
- Centralized and decentralized solutions
- Single to multiple pack stations
- Tailor-made integration



FROMM – your one-stop partner for tailor-made and off-the-shelf solutions.

Our airpad product range

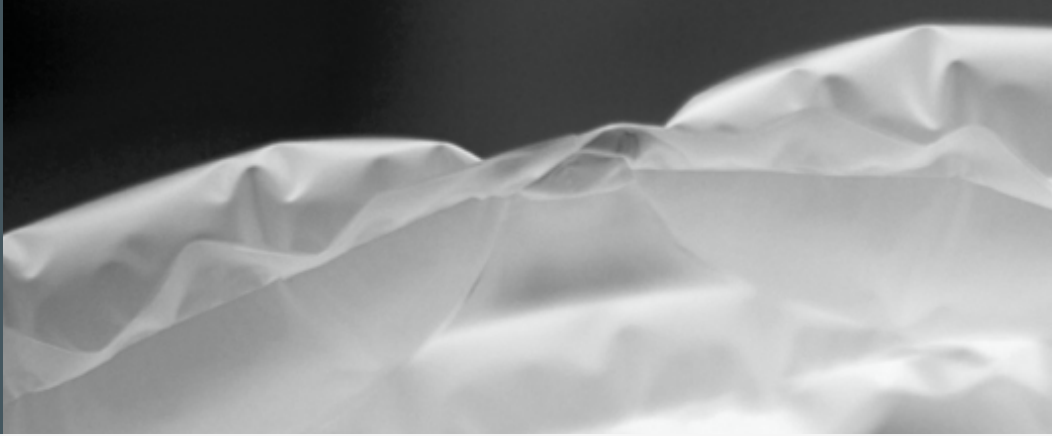

AP100 Compact airpad system

- Ideal for decentralized packing stations
- Small footprint
- Easy to use
- Integrated blower
- 12 – 16 m/min
- Film width of 200 – 400 mm
- Integration with hoppers, bins and other accessories

Applications	Pads
Void filling	200 x 135 mm
Block and aBrace	200 x 200 mm
Cushioning	400 x 150 mm (2 pads)
	400 x 150 mm (8 pads)

AP150 Compact bubble on-demand airpad system

- Ideal for all wrapping needs
- Easy to use
- Integrated compressor
- Fast throughput 18 m/min
- Film width of 200 – 400 mm
- Optional winder, 50 m roll in < 3 min

Applications	Pads
Wrapping	400 x 300 mm

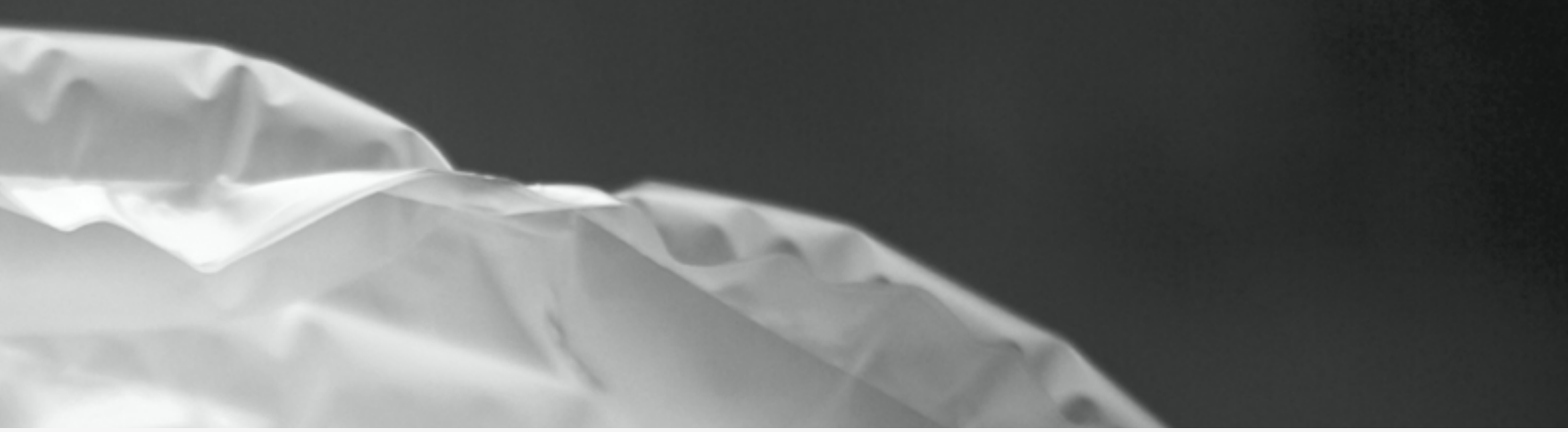

AP250

Multiple cushion size airpad system

- Configurable for multiple cushion sizes from same film roll
- Throughput 8 – 12 m/min
- Film width of 210 mm
- Optional hopper

Applications

Void filling
Block and Brace
Cushioning

Pads

120 to 400 mm
210 or 150 mm width

AP502/503

The high-end airpad system for centralized production

- Industrial, heavy-duty design
- 49 variations of cushions with one film
- Pre-set programs, easily selectable on screen
- Wide range of films from 25 to 65 microns
- Wide range of materials: PE, PE-PT, PE-PA, laminated, coextruded
- AP 502 with integrated winder
- AP 503 with multifunctional moveable storage bin

Applications

Void filling
Block and Brace
Cushioning
Wrapping

Pads

All pad types and pad sizes
Heavy-duty pads

Our AP100 and AP150 accessories

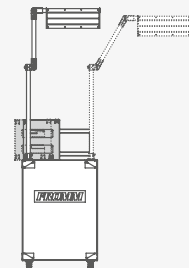
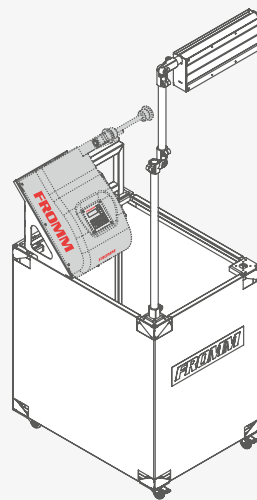
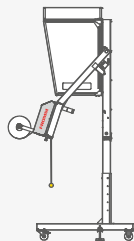
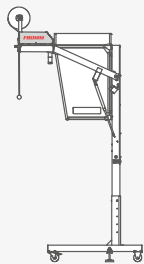
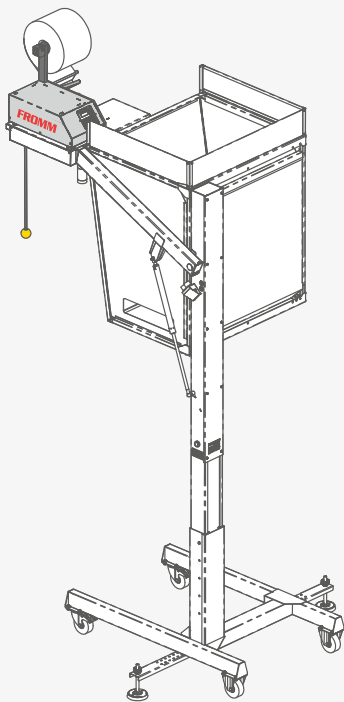

AP100

Manual overhead hopper system

- Ideal for decentralized applications
- Space-saving conception for flexible implementation
- Manual machine lift for easy film loading
- Adjustable height
- Multiple openings for single- or multiple-operator use
- Automatic filling of the bin
- Silent operation without blower

AP100

Mobile bin with articulated arm/pad holder

- Ideal for decentralized or remote pack stations
- 4 wheels for mobile use
- Compatible with 200 mm and 400 mm pads
- Articulated arm and adjustable pad holder for use from two sides
- Can serve a second packing stations with additional articulated arm and pad holder
- Automatic, sensor-controlled filling of the bin
- Fast assembly and easy installation

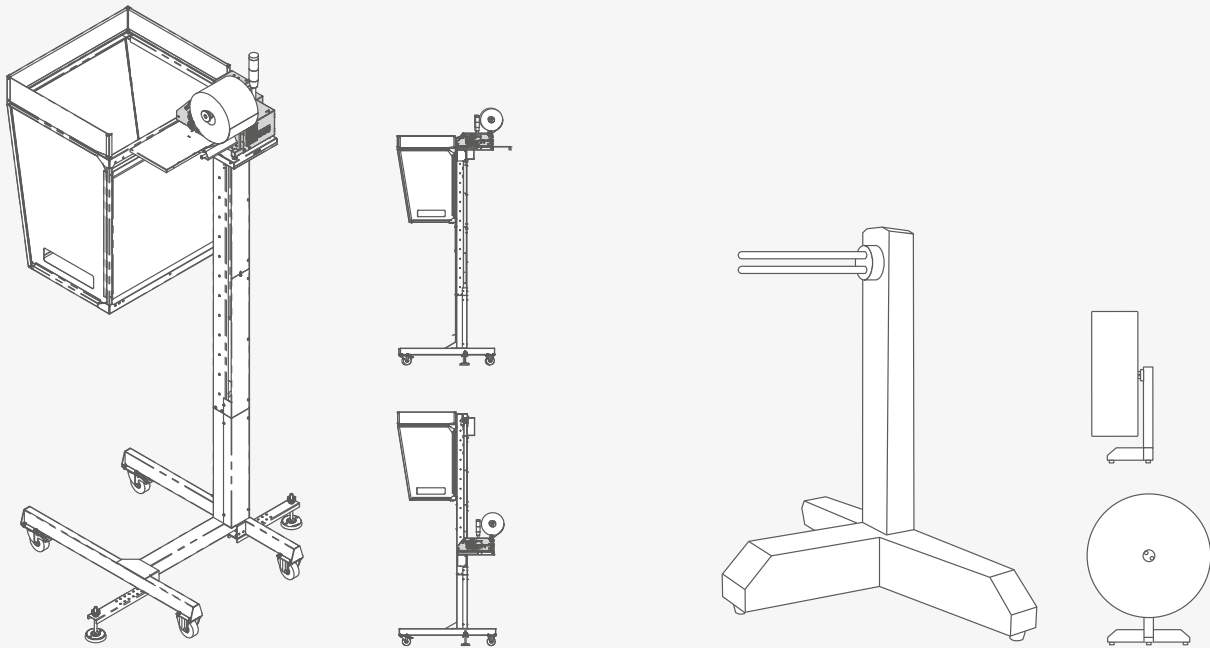

AP100

Electrical overhead hopper system

- Same as AP100 manual hopper system but with electrical machine lift for effortless film loading

AP150

Electrical winder

- Ideal for remote packing stations
- Generates one roll of bubble film material in less than 3 minutes
- 2-way communication with AP150 machine
- Fully automatic, sensor-controlled operation
- Small footprint
- Robust design

Tailor-made Solutions

FROMM – Your one stop partner for custom made solutions.

FROMM is present at all steps of your project, from identification of the needs to the installation and even full maintenance of the line.

FROMM's end-of-the line expertise leads to reliable solutions, increased productivity and improved ergonomics.

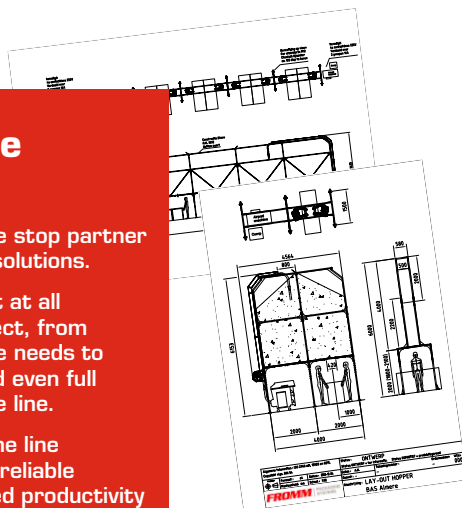



Quality

FROMM is a family-owned company headquartered in Switzerland. Since its establishment in 1947, FROMM develops and produces systems and consumables for securing goods in transport: strapping systems, stretch wrapping machines and the patented Airpad™ air cushioning system. FROMM's end-of-line expertise and uncompromising, dependable quality is resumed in two words: no problem. All FROMM systems and consumables are developed and produced in FROMM research centers and factories certified ISO 9001.

Proximity

FROMM considers employees as its most valuable asset. In order to ensure a high level of expertise, FROMM invests in people and training. Our qualified specialists ensure professional advice, prompt customer service and reliable maintenance. FROMM operates worldwide through 35 subsidiaries in Europe, North and South America, South Africa, Asia and Australia, as well as a multitude of specialized long term sales partners throughout the world. Wherever you are, FROMM is close to you.

Sustainability

FROMM's high vertical integration, from product design to sales, enables close control over the entire production process, reducing environmental burden wherever possible. Besides optimizing its production processes, FROMM has developed techniques for recycling plastic materials. In its ISO 9001/14001/50001 certified plant near Leipzig, FROMM recycles PET bottles, producing agglomerates and regranulates for diverse industrial applications. FROMM's STARstrap™ plastic strappings are produced exclusively from recycled bottles.

FROMM – Swiss quality for strapping, wrapping and void filling.

FROMM | AIRPAD SYSTEMS

676, Monarch Ave Unit 6, Ajax, LIS 4S2
905-428-3444
sales@frommpackaging.ca